

EO-CW720 LASER POWER SUPPLY OPERATION MANUAL

VERSION1.3

November, 2008

SINO-LASER (BEIJING) INC

2F, Jia 2 Building, Xihongmen Road 26
Daxing District
Beijing, P.R. China
Postal Code: 100076
Tel: (86)-10-60299801
Fax:(86)-10-62258470
E-mail: liyong@sino-laser.com
Website: www.sino-laser.com

TABLE OF CONTENTS

| | |
|---|------------|
| WARRANTY | III |
| Limitations | III |
| Returning an Instrument | III |
| Claims for Shipping Damage | III |
| SAFETY INFORMATION | IV |
| Safety Information and the Manual | IV |
| General Safety Considerations | IV |
| Safety Notice | V |
| CHAPTER 1 | 1 |
| GENERAL INFORMATION | 1 |
| Product Overview | 1 |
| System Configuration | 1 |
| Main Specifications | 1 |
| CHAPTER 2 | 3 |
| OPERATION | 3 |
| EO-CW720 Familiarization | 3 |
| Front Panel | 3 |
| Rear Panel..... | 3 |
| Warm-up and Environmental Considerations | 5 |
| Installation | 5 |
| AC Power Considerations | 5 |
| Operation | 5 |
| Power-up Sequence | 5 |
| Turn Off System..... | 6 |
| Mode Selection | 6 |
| Display Selection | 6 |
| LD On/Off control | 6 |
| Adjusting LD current | 6 |
| External monitor | 6 |
| External pulse modulation | 7 |
| Panel functions & Interfaces | 7 |

WARRANTY

Sino-Laser (Beijing) Inc warrants this instrument to be free from defects in material and workmanship for a period of one year from date of shipment. During the warranty period, Sino-Laser repair or replace the unit, at our option, without charge.

Limitations

This warranty does not apply to fuses, lamps, defects caused by abuse, modifications, or to use of the product for which it was not intended.

This warranty is in lieu of all other warranties, expressed or implied, including any implied warranty of merchantability or fitness for any particular purpose. Sino-Laser shall not be liable for any incidental, special, or consequential damages.

If a problem occurs, please contact **SINO-LASER** with the instrument's serial number, and thoroughly describe the nature of the problem.

Returning an Instrument

If an instrument is to be shipped to Sino-Laser for repair or service, be sure to:

1. Obtain a Return Authorization in writing from **SINO-LASER** Customer Service.
2. Attach a tag to the instrument identifying the owner and indicating the required service or repair. Include the instrument serial number from the rear panel of the instrument.
3. Place the instrument in the packing container with at least 3 inches (7.5 cm) of compressible packaging material. **Shipping damage is not covered by this warranty.**
4. Secure the packing box with fiber reinforced strapping tape or metal bands.
5. Send the instrument, transportation pre-paid, to **SINO-LASER**. **SINO-LASER** recommends you insure the shipment.

Repairs are made and the instrument returned transportation pre-paid. Repairs are warranted for the remainder of the original warranty or for 90 days, whichever is greater.

Claims for Shipping Damage

When you receive the instrument, inspect it immediately for any damage or shortages on the packing list. If the instrument is damaged, file a claim with the carrier. The factory will supply you with a quotation for estimated costs of repair.

SAFETY INFORMATION

Safety Information and the Manual

Throughout this manual, you will see the words *Caution* and *Warning* indicating potentially dangerous or hazardous situations which, if not avoided, could result in death, serious or minor injury, or damage to the product. Specifically:

CAUTION

Caution indicates a potentially hazardous situation which can result in minor or moderate injury or damage to the product or equipment.

WARNING

Warning indicates a potentially dangerous situation, which can result in serious injury or death.

General Safety Considerations

If any of the following conditions exist, or are even suspected, do not use the instrument until safe operation can be verified by trained service personnel:

- ☞ Visible damage
- ☞ Severe transport stress
- ☞ Prolonged storage under adverse conditions
- ☞ Failure to perform intended measurements or functions

If necessary, return the instrument to **SINO-LASER**, or authorized local **SINO-LASER** distributor, for service or repair to ensure that safety features are maintained.

Safety Notice

This section describes the safety symbols and classifications. Technical specifications including electrical ratings and weight are included within the manual. See the Table of Contents to locate the specifications and other product information. The following classifications are standard across all **SINO-LASER** products:

- ✍ Indoor use only
- ✍ Ordinary Protection: This product is NOT protected against the harmful ingress of moisture.
- ✍ Class I Equipment (grounded type)
- ✍ Mains supply voltage fluctuations are not to exceed $\pm 10\%$ of the nominal supply voltage.
- ✍ Pollution Degree II
- ✍ Installation (over voltage) Category II for transient over voltages
- ✍ Maximum Relative Humidity: $< 80\%$ RH, non-condensing
- ✍ Operating temperature range of $10\text{ }^{\circ}\text{C}$ to $40\text{ }^{\circ}\text{C}$
- ✍ Storage and transportation temperature of $-40\text{ }^{\circ}\text{C}$ to $70\text{ }^{\circ}\text{C}$
- ✍ Maximum altitude: 3000 m (9843 ft)
- ✍ This equipment is suitable for continuous operation.

CHAPTER 1 GENERAL INFORMATION

This manual contains operation and maintenance information for the EO-CW720 laser diode driver.

Product Overview

The EO-CW720 is a laser diode driver with a maximum output capacity of 720W at 24V/30A. The power supply can accept the external control for current setting and pulse modulation. 2 external interlocks inputs enable the power supply works together with the external temperature controller or water chiller safely. The multiple built-in protection features ensure that the supply output is transient-free and bounded under all conditions.

Features of the EO-CW720 include:

- ✍ Intuitive front panel layout
- ✍ Fully independent, precision current limit control
- ✍ Safe OUTPUT off/on switch

The LD current and the LD temperature can be set by user as per his application requirements.

System Configuration

The EO-CW720 Laser Power Supply(LPS) is configured by a 30V/30A DC power supply, a LD driver which is providing output control, a interface board establish the external control connection.

Main Specifications

| | |
|-----------------------------------|--------------------|
| CURRENT OUTPUT¹ | |
| Current Range: | 0 to 30A, floating |
| Compliance Voltage: | >24 Volts |
| Stability (at 30A): | <30mA |
| Noise and ripple (at 30A): | <40mA |
| OPERATION MODE | |

| | |
|------------------------|--|
| Mode | CW at internal control, external control available |
| Pulse control | External control available |
| Interlock | 2 interlock inputs available |
| DISPLAY | |
| Type: | 4 digits LED display |
| Display items | Actual output current, current setting |
| Status indication | LED indicators |
| GENERAL | |
| AC Power: | 200-245 AC nominal line voltage, 50 Hz |
| Operating Temperature: | 10-40°C |
| Storage Temperature: | -40°C - 70°C |
| Warm-up: | 10 minutes for rated accuracy |

CHAPTER 2 OPERATION

This chapter is a guide to setting up and operating the EO-CW720. The controls and connectors are described, and then step-by-step instructions for connecting and using the EO-CW720 are presented.

EO-CW720 Familiarization

The following sections are provided to familiarize the user with features found on the EO-CW720.

Front Panel

The EO-CW720 front panel is shown as below

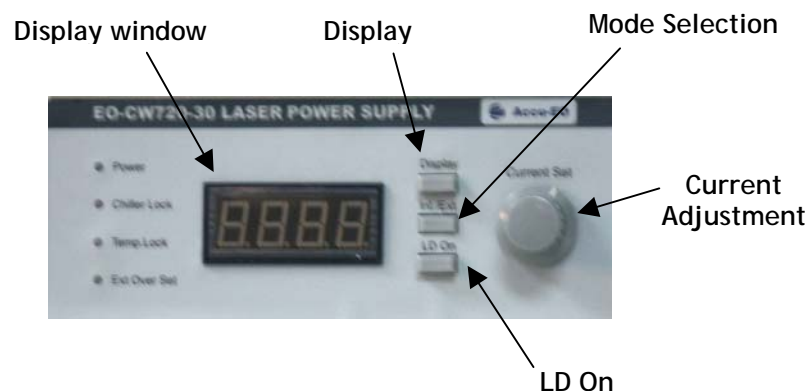

Rear Panel

The rear panel contains the connectors to external system and laser head, power cord receptacle and fuse exchange unit. The laser head connector output LD+ (in red line) and LD- (in back line). User interface provide connection with the external system.

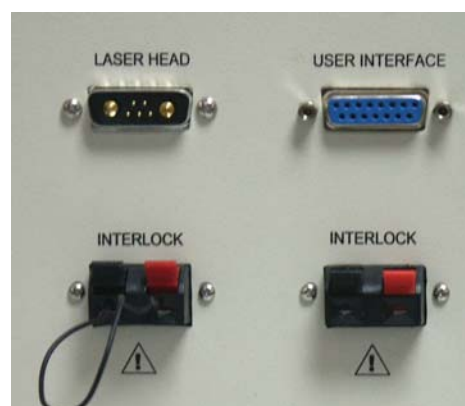

Output Connectors

Interlock

There are two Interlock receivers, each of them has two line inputs. While the two lines are short-circuit, the LPS is recognizing the external enable the output LD driving current. When both of the interlocks are enabled, short-circuit, the driver is enabled

to output. While either one of the two interlock disable, the two lines are open, the LPS cannot output current to drive the laser diode load. For LPS's self-running without external system, the inputs should be short-circuit to enable the operation. To connect the external interlock lines with the LPS, push the lock-switch to enable the line end get into the connection hole, release the pushing can lock the the lines.

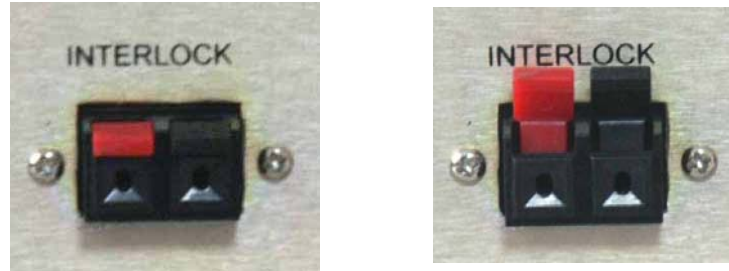

User Interface

This is a 15-pin D-sub connector with female pins. The following table summarizes their functions:

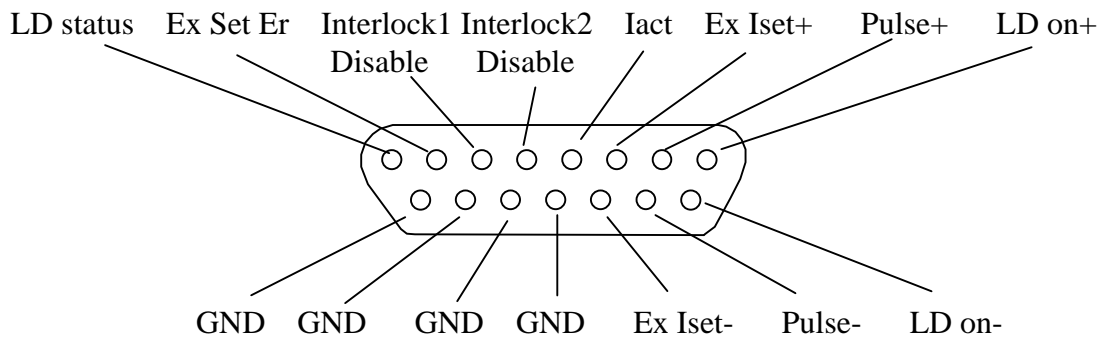

| PIN # | NAME | DESCRIPTION/SPECIFICATIONS |
|-------|----------------|---|
| 1 | LD on+ | Input TTL low to enable the LD driving output when the power supply set as "External" control mode. TTL high or open will disable the output in external mode |
| 9 | LD on- | |
| 2 | Pulse+ | Input TTL high to enable the LD driving output when the power supply set as "External" control mode. TTL low will disable the output in external mode. Input pulse chain will control the output in current pulse |
| 10 | Pulse- | |
| 3 | Ex Iset+ | The voltage between pin3 and pin 11 will set the output current when in external mode at the rate of 10A/V This input will not affect the current setting in internal mode |
| 11 | Ex Iset- | |
| 4 | Iact | This out voltage to the GND reflect the actual current output at the rate of 10A/V |
| 5 | Interlock 2 Er | When out put TTL high means the interlock 2 disable the output |
| 6 | Interlock 1 Er | When out put TTL high means the interlock 1 disable the output |
| 7 | Ext set er | TTL high for External Iset over the range acceptable |
| 8 | LD status | TTL high for power supply working error, low for all right |

| | | |
|-----------------|-----|--------------------------------|
| 12,13, 14,15 | GND | Signal ground for pin4,5,6,7,8 |
|-----------------|-----|--------------------------------|

Warm-up and Environmental Considerations

The EO-CW720 should be operated at an ambient temperature between 10 and 40 °C. Storage temperatures should be in the range of -40° C to 70 °C. In order to achieve rated accuracy, the EO-CW720 should be warmed up for 10 minutes before use.

Note: To prevent overheating, the EO-CW720 must be kept well ventilated. Allow at least 1/2 inch clearance around the vent holes.

Installation

Before plugging in the EO-CW720 to your AC power source, make sure that the AC power voltage is within the acceptable arrange the system required.

AC Power Considerations

The EO-CW720 can be configured for operation with nominal line voltages of 200-245VAC 50Hz. The unit is configured at the factory for the appropriate range. Make sure the AC input power matches the range marked on the rear panel.

WARNING

To avoid electrical shock hazard, connect the instrument to properly earth-grounded electrical supply only. Failure to observe this precaution can result in severe injury or death.

Operation

Power-up Sequence

With the EO-CW720 properly connected to an AC power source, pressing up the AC POWER switch up on the front panel will power-up the system. After one second of turning the power, the LED display will on. The power supply will work at the mode set while turning up the power.

WARNING

Before turning on the power supply, user must make sure that the LD on button is at the off position to avoid making output when turning on the power.

Turn Off System

To protect your LD and the system, it should follow the correct procedure when turn off EO-CW720.

1. Turn off LD output by the pushing “LD on” button to make sure the there is no output to the LD;
2. Turn off the power key by pushing the power switch down.

Mode Selection

The mode selection button on the front panel enable user to select internal mode or external mode. When the power supply is working in Internal mode, the current setting and output on/off control will be depending on the front panel operation. User can set the output current and on/off the output by the adjustment node and the button on the front panel. When select External control mode by pushing down the mode selection button, the current setting, LD on/off will be controled by the externaql system via DB15 connector. The external control should be as per the pin definition of the connector.

Display Selection

User can push the “Display” button to select the data to see. When the button is up, the output current is displied when pushing down, the output voltage is displaied.

LD On/Off control

In internal mode, the LD On button up position means no output and pushing down the button will enable the output. When working at External mode, this button should be keeping at up position then the output on/off will be controlled by the external LD On signal .

Adjusting LD current

In internal mode, the LD current can be adjusted by the node on the front panel. Turning the node can adjust the output larger or smaller while the current display indicate the value set.

External monitor

The external system can monitor the power supply's operation via the DB15

connector. Iact signal indicates the actual current output; Interlock1 and 2 indicate the interlock status; LD status indicates the LD on/off status.

External pulse modulation

When working at External mode, input pulse chain in TTL can control the output in current pulse form. The input pulse width and frequency is the current's output.

Panel functions & Interfaces

